

EN **Garage door drives RolloPort SXS DuoFern**
Translation of the Original Operating and Assembly Manual

Item No.: 4505 90 61 (three-section rail)



with your purchase of this **garage door drive**, you have decided in favour of a quality product manufactured by RADEMACHER. Thank you for the trust you have placed in us.

The **RADEMACHER garage door drive** has been designed in an effort to achieve the greatest possible ease of operation. Having applied uncompromising quality standards and thorough testing, we are proud to be able to present this innovative product to you.

It's brought to you by all the highly-qualified personnel here at RADEMACHER.



These instructions...

...describe how to install, connect and operate the **RolloPort SX5 DuoFern**.



Before you begin, please read these instructions through completely and follow all the safety instructions.

These operating instructions form a component of the product. Please store them in an accessible place.

Please pass the operating instructions on when handing over the garage door drive to other people or future owners.

Damage resulting from non-compliance with these instructions and safety instructions will void the guarantee. We assume no liability for any consequential damage.

i	Dear Customer,	2	11.	Programming	24
1.	Scope of delivery	4	11.1	Setting end points / setting the upper end point	25
2.	General view	5	11.2	Setting the lower end point	25
3.	Key to symbols	6	11.3	Carry out reference run for power measurement	26
4.	Safety information	6	11.4	Adjust power limiting as required	27
5.	Proper use	8	11.5	Alarm setting	28
5.1	Operating conditions	8	11.6	Automatic closing time setting	28
6.	Improper use	9	11.7	2000 cycle alarm setting	29
7.	Approved garage door types	10	11.8	Opening speed setting	30
7.1	Inadmissible types of garage door	10	11.9	Back-jump function setting	31
8.	Functional description	11	11.10	Conclude programming	32
8.1	Brief description of the convenience functions	11	12.	Logging on/off manual transmitters and/or SmartHome Box	33
8.2	Functional description / emergency release	12	13.	Application and installation of a light barrier	34
8.3	Functional description / obstacle detection	12	14.	Connecting additional electrical equipment	34
8.4	Monthly checks on the obstacle detection system (power limiting)	13	14.1	Connection diagram for additional electrical equipment	35
9.	Maintenance	13	15.	Manual door operation	36
10.	Important assembly instructions	14	16.	Instructions for the user	37
10.1	Required tools	15	17.	Technical Specifications	38
10.2	Remove the door locks	15	17.1	Permitted garage door dimensions	38
10.3	Take measurements	16	18.	Troubleshooting	39
10.4	Assembly of the rails	17	19.	Simplified EU Declaration of Conformity	40
10.5	Tension the toothed belt	17	20.	Environmentally compatible disposal	40
10.6	Connect the door drive housing to the rail	18			
10.7	Connect the door drive housing to the rail (90° drive assembling)	19			
10.8	Attachment of the drive and rail	20			
10.9	(A) Installation of the header bracket (1)	21			
10.10	(B) Installation of the fixing bracket (5) at the drive head (7)	21			
10.11	(C) Installation of the door bracket (8)	22			
10.12	(D) Installation of the middle support clip (13)	23			
10.13	(E) Installation on the ceiling with perforated brackets	23			
10.14	Important notes after installation	24			
10.15	Attach safety notices with warning information	24			
10.16	Establish operational readiness of the door	24			

i 1. Scope of delivery

EN

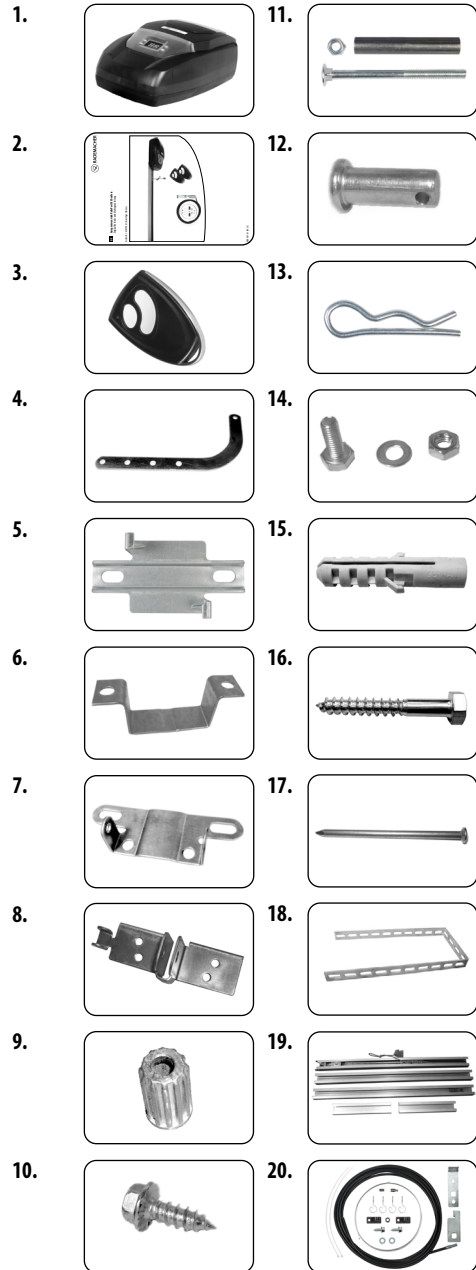

After unpacking the product, please compare the contents of the package with this list:

1. 1 x Drive
2. 1 x Operating instructions
3. 2 x Manual transmitters
4. 1 x Door connector, bent
5. 1 x Middle support clip
6. 3 x Fixing bracket
7. 1 x Header bracket
8. 1 x Door bracket
9. 1 x Connector
10. 8 x Self-tapping hexagon screw (6 x 15 mm)
11. 1 x Bolt (6 x 80 mm) with hexagon nut and protective sleeve
12. 1 x Bolt (8 x 20 mm)
13. 1 x Securing bolt (2 x 20 mm)
14. 4 x Bolt (8 x 20 mm) with hexagon nut, protective sleeve and plain washer
15. 6 x Wall plug (10 mm)
16. 6 x Hexagon screw 8 x 60 mm)
17. 1 x Spike
18. 2 x perforated brackets
19. – three-section rail + two connectors
20. 1 x External release

i 2. General view

EN

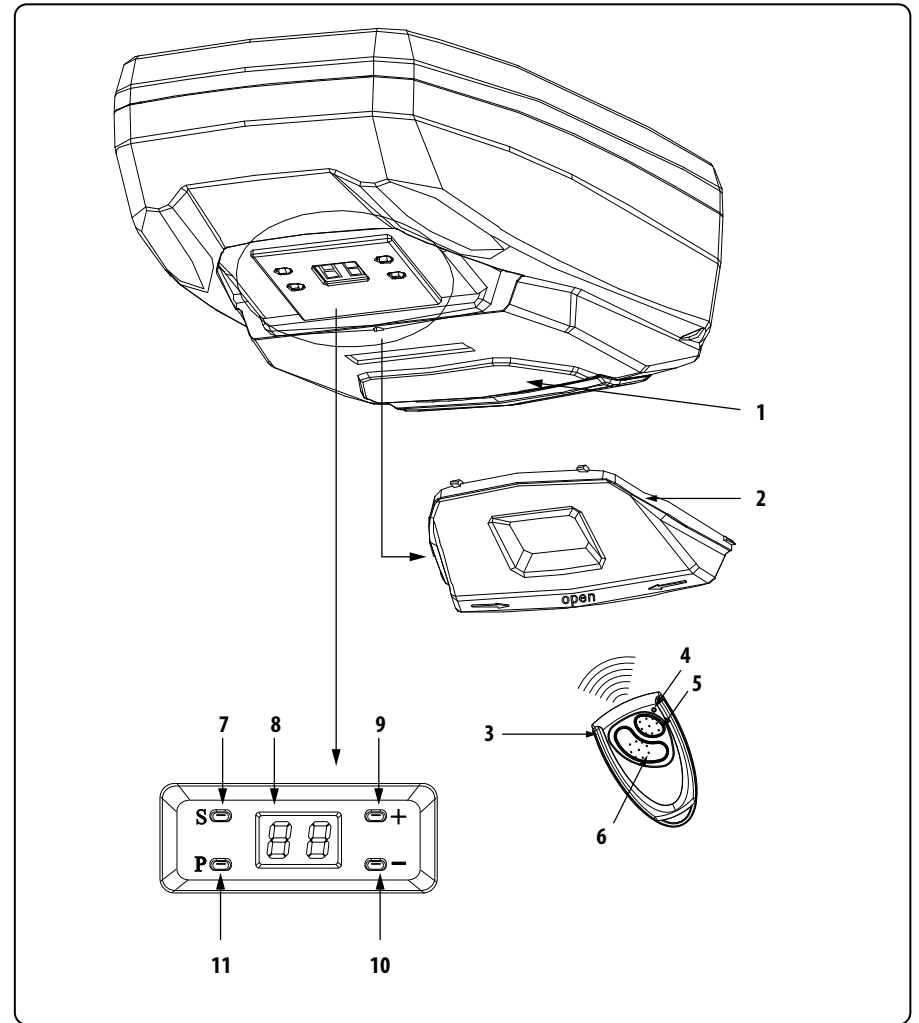

Legend

- | | |
|---|--------------------------------|
| 1 = Drive, including lighting | 7 = Set button (S) |
| 2 = Cover panel (removable) | 8 = Display (2 digit) |
| 3 = Manual transmitter | 9 = Button for adjustment (+) |
| 4 = Control LED | 10 = Button for adjustment (-) |
| 5 = 1 Buttons on the manual transmitter | 11 = Programming button (P) |
| 6 = 2 Buttons on the manual transmitter | |



Risk of fatal electric shock.

This sign warns of danger when working on electrical connections, components, etc. It requires that safety precautions be taken to protect the life and health of the person concerned.



This symbol warns of malpractices that can result in personal injury or property damage.

Please ensure that all instructions marked with this symbol are followed.



Failing to observe all of the information and safety instructions contained in this manual can lead to severe personal injury, e.g. by being trapped by the door.

Follow all of the information in this operating and assembly manual in order to comply with the safety regulations in standards EN 13241-1, EN 12445 and EN 12453 and only operate the door system in accordance with the standard once it has been inspected by a qualified engineer.



Work on electrical systems entails the risk of fatal electric shock.

- ◆ All work on the drive and the electrical system may only be carried out by a qualified electrician in accordance with these operating instructions, see page 34.
- ◆ Always remove the mains power adapter from the socket before performing any work on the door or the door drive (e.g. cleaning, maintenance or the replacement of parts).



The use of defective equipment can lead to personal injury and damage to property (electric shocks or short circuiting).

- ◆ Never use defective or damaged equipment.
- ◆ Check the drive and mains cable to ensure they are free from damage.



Important safety information which can lead to property damage if not observed.

Please pay particular attention and carefully follow all instructions marked with this symbol.

NOTE!

This is to draw your attention to information that is important for trouble-free operation.

- ◆ If the power cable is damaged, it must be replaced by the manufacturer, its service agent or similarly qualified persons in order to avoid a hazard.
- ◆ Please consult our customer service department in the event that you discover damage to the equipment.



Faulty doors can result in serious injury.

- ◆ The operation of the door must not be hindered by badly adjusted springs or poorly functioning door mounts or door constructions.
- ◆ There is a risk of injury due to the tightly tensioned door springs. Never attempt to replace the door springs yourself.
- ◆ Have all work on the door mechanics and springs carried out by a qualified engineer.



Power-driven doors entail the risk of crushing and shearing at the closing edge.

- ◆ Ensure that during operation there are no persons in the swivelling range of the garage door.
- ◆ If the garage door is automatically driven (e.g. in combination with the RADEMACHER SmartHome Box) and can therefore start unexpectedly, it must be ensured that it is not possible for anyone to be located within the motion range of the door.



Important safety instructions.

It is important for the safety of persons to follow all instructions. Save these instructions.



Incorrect use leads to an increased risk of injury.

- ◆ Never reach into the moving door or into moving parts.
- ◆ The door should never be operated out of sight without additional safety equipment (e.g. light barrier), see page 34.
- ◆ Instruct all persons who operate the garage door in the safe use of the garage door drive.
- ◆ This device may be used by children from 8 years of age upwards as well as by persons with reduced physical, sensory or mental capacities or with lack of experience and knowledge if they are supervised or have been instructed on how to use the device safely and if they understand what dangers may result from this.
- ◆ Do not allow children to play with the door or with the manual transmitter.
- ◆ Please store the manual transmitter in such a way that it cannot unintentionally be operated, for example, by playing children.
- ◆ Cleaning and user maintenance may not be carried out by children without supervision.
- ◆ Do not allow anyone to go through under the moving door.
- ◆ Keep children away when the door is moving.
- ◆ Only drive through the door when it is fully open and at a standstill.



If safety attachments are defective or out of operation there is a risk of injury or damage to property.

- ◆ Before commissioning and thereafter once a month, inspect for correct functioning of the safety equipment (e.g. the power limiter).
- ◆ Never attempt to deactivate the safety equipment.
- ◆ Keep the door limit stop on the ground free of ice, snow, dirt and stones.



The mains socket and plug must be easily accessible at all times.

Opener service life is 25.000 cycles.

Each steel wire rope shall have a safety factor not smaller than 6 (minimum breaking strength / static load of one rope).

Rope drums shall have a pitch circle diameter (PCD) at least equal to 20 times the rope diameter.

Use the garage door drive only:

- ◆ for opening and closing of approved garage doors, see page 10 / 38.
 - ◆ for non-commercial use
 - ◆ according to the information and security requirements given in this manual.
- Any other usage would be regarded as improper use.



- ◆ Garage doors with automatic closing (e.g. RolloPort SX5 DuoFern) must be fitted with an additionally connected safety device (e.g. light barrier), in addition to the standard equipped power limiter.
- ◆ The RolloPort SX5 DuoFern may only be used in automatic mode (automatic closing) with an additionally connected light barrier, see page 34.



A lack of maintenance can lead to personal injury through damage to your garage door drive, the associated safety devices and the garage door system.

- ◆ Observe all maintenance intervals, see page 13.
- ◆ Test the safety equipment regularly, see page 13.



Failing to observe all of the information contained in this manual can lead to severe personal injury, e.g. by being trapped by the door.

Pay attention to all of the information. In order to comply with the safety regulations in standards EN 13241-1, EN 12445 and EN 12453, it is particularly important that this operating and assembly manual is followed during the installation process.

i 5.1 Operating conditions

- ◆ Only operate the RolloPort garage door drive in dry rooms.
- ◆ The garage door must be able to be opened and closed easily by hand and must not jam.
- ◆ Ensure that the overhead ceiling runners are always free of grease and dirt. Dirty overhead ceiling runners hinder proper operation.
- ◆ An easily accessible 220 - 240 V / 50 - 60 Hz socket must be available at the installation site.

- ◆ Remote operation with a manual transmitter as well as the installation and operation of the DuoFern radio system and its components (e.g. RolloPort SX5 DuoFern) is only permitted for those systems and devices where a malfunction in the transmitter or receiver would not cause a danger to personnel or property or where this risk is already covered by other safety equipment.

NOTE!

Radio systems which transmit on the same frequency can cause interference.



Using the garage door drive for purposes other than previously mentioned is impermissible.

- ◆ This applies especially to:
 - all manual radio transmitters
 - the RolloPort SX5 DuoFern
 - the DuoFern radio system and its components

Never use the above mentioned components for remote control of appliances and systems with increased safety-relevant requirements or where there is an increased accident risk. Such applications require additional safety equipment. Observe the respective statutory regulations for the installation of such systems.

- ◆ Do not install the garage door drive outside.

The RolloPort garage door drive may not be used for the following areas of application:

- ◆ in commercial establishments
- ◆ to drive other objects
- ◆ in continuous operation



Watch the moving door and keep people away until the door is completely opened or closed.



Warning

- ◆ The drive shall be disconnected from its power source during cleaning, maintenance and when replacing parts.
- ◆ The drive must not be used with a door incorporating a wicket door without monitoring.
- ◆ If re-adjustment does not restore the correct operation, call for authorised service.



The RolloPort SX5 DuoFern may not be used without additional light barriers, see page 34.



Incorrectly performed structural alterations result in the risk of injury.

Do not carry out any structural alterations to the drive, the garage door or any existing safety equipment which deviate from the measures described in this manual. Such alterations endanger the operating safety.



If a wicket door is installed, the door position must be monitored. It must be ensured that the drive is not active if the door is not closed.

Information about product liability

The manufacturer is not liable for damage resulting from incorrect or improper use (see warranty conditions).

i 7. Approved garage door types

EN

- ◆ swing out standard up-and-over doors
- ◆ sectional doors

The doors must move smoothly and comply with the regulations of the following standards: EN 12453 and EN 12604.

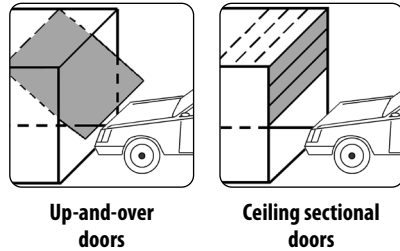

Up-and-over doors

Ceiling sectional doors

i 7.1 Inadmissible types of garage door



Doors which require tilting and rotating movements may not be operated with the RolloPort garage door drive.

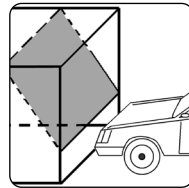

Non-swinging tilting door

i 8. Functional description

EN

The RolloPort SX5 DuoFern is a electronic garage door driver suitable for use with all standard up-and-over and sectional doors (see page 10).

Flexible installation options

The 90° rotatable drive unit offers flexible installation options. The quiet-operation belt drive provides secure power transmission.

Extensive convenience functions

The RolloPort SX5 DuoFern offer extensive convenience functions (see chap. 8.1) for individual customisation on-site.

Both garage door drives are equipped with an obstacle detection system including reversing function and have an internal emergency release for manual operation in case of power failure.

Manual control on site

Additionally, an external switch can be connected for manual control on site.

RolloPort SX5 DuoFern

The RolloPort SX5 DuoFern is designed for use within a radio network and can be integrated and controlled with a RADEMACHER SmartHome Box or other DuoFern controllers.

The RolloPort SX5 DuoFern must be connected to the DuoFern network.



In order that the RolloPort SX5 DuoFern can receive control commands from the DuoFern network, you must log it in to a SmartHome Box or another DuoFern device, see page 33.



To do so, please read the operating instructions for the respective DuoFern device.

Further information on the DuoFern system can be found at:

<http://www.rademacher.de/duofern>

i 8.1 Brief description of the convenience functions

Intelligent microcomputer

Intelligent, computerised, exact positioning of travel, prompt power determination, reverses if obstructions are met.

Drive

Low noise, soft start and soft stop protect the drive and ensure a long service life.

Display information

Operating mode and digital menu shown in display:

- ◆ L = Normal mode
 - ◆ F/H = A fault has been detected by the electronics *
 - ◆ A = The light barrier has been interrupted *
- * See page 39 (Fault rectification)

Cryptoguard

Rolling code technology provides billions of code combinations and makes every manual transmitter unique, thereby protecting against unauthorised access.

Alarm unit

The alarm sounds when the door is left open for longer than 10 minutes. The alarm stops when the door is closed again (refer to "Alarm settings" on page 28).

Emergency release

The door can be manually operated by pulling down on the emergency release cable in the event of power failure.

Automatic closing function

The automatic closing time of the door can be set from 30 to 240 seconds, please refer to page 28 / 29.

2000-cycle alarm

When the drive has run 2000 cycles, it will beep to remind the user to service the mechanical system, please refer to page 29.

i 8.1 Brief description of the convenience functions

EN

Lighting

The garage door drive has an integrated energy-saving LED lighting system which is switched on after each switching impulse and which goes off again automatically after 3 minutes.

Additional connecting options for external accessories and safety unit

In addition you can connect an external switch and an infrared light barrier, see page 34.

Opening speed:

The opening speed can be adjusted in three stages. It is configurable between 11 cm/s up to 19 cm/s (factory setting), see page 30.

Back-jump function

With active back-jump function, the drive moves briefly in the respective opposite direction after reaching the end point. This reduces mechanical strain in both end positions and enables easier operation of the emergency release (see page 31).

The back-jump function can be activated and deactivated.

i 8.2 Functional description / emergency release

In the event of a power cut, the door can be operated manually by pulling the emergency release cable.



There is a risk of injury. The door can fall down in an uncontrolled manner (for example, if the springs are weak or broken, or if the door is not properly balanced).

- ◆ Always close or open the door fully after each release.
- ◆ The emergency release is not intended for everyday use.



i 8.3 Functional description / obstacle detection

The drive has an automatic obstacle detection system (through internal monitoring of power).

If the door encounters an obstruction when closing or opening, the drive stops the door automatically and moves it in the opposite direction until it reaches the corresponding end point.

After removing the obstruction, you can operate the garage door drive normally again.

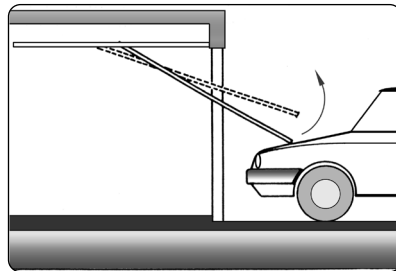

8.4 Monthly checks on the obstacle detection system (power limiting)

EN

1. Run the door into the fully open position.
2. Place a 50 mm high object, e. g. a wooden block, in the direction of travel of the door.
3. Close the door by actuating the manual transmitter.
4. If the door hits an obstruction when closing, the drive automatically stops and opens the garage door fully.
5. After this, remove the obstruction.
6. After removing the obstruction, you can operate the garage door drive normally again.

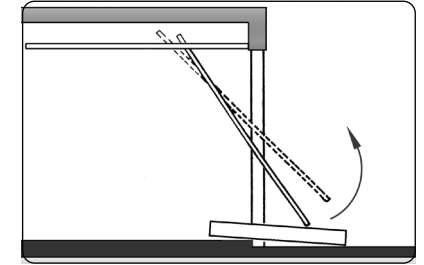

Placing an approx. 50 mm wooden block in the direction of travel of the door.



If necessary, correct and check the alignment once again, as an incorrect alignment cause pose a threat, see page 27.

If the subsequent adjustment does not restore correct operation, please contact our authorised Service department.



9. Maintenance



Defective door systems and safety equipment result in the risk of injury.

For your safety, you should comply with the recommended maintenance intervals for your door system, including all safety equipment.

Maintenance interval:

Have the door system inspected by a specialist company before commissioning and then as required, but at least once a year.

Regular checks of wearing parts:



There is a risk of injury due to defective or worn components.

Check the system therefore regularly for signs of wear, damage or lack of balance of the door.

Do not use the door under any circumstances if repairs or adjustments need to be made, as a faulty or imbalanced door can lead to injuries.

Check all:

- ◆ screwed connections to ensure they are tight
- ◆ cables for damage
- ◆ springs and fixing parts



There is a risk of injury due to the tightly tensioned door springs.

- ◆ Never attempt to replace the door springs yourself.
- ◆ Have all work on the door mechanics and springs carried out by a qualified engineer.



10. Important assembly instructions

EN

Important instructions for a safe installation.
Follow all installation instructions carefully.



Incorrect installation can lead to serious injuries.



Before assembly, check...:

- ◆ ...whether your drive is suitable for the type of garage door and the garage door height.
- ◆ ...that the door is in perfect mechanical condition. The door must be smooth running and be balanced. Check whether it opens and closes properly.
- ◆ Open the door approximately 1 m and then let go. A balanced door should remain in this position. If not, have your door adjusted by a specialist company.
- ◆ The operation of the door must not be hindered by badly adjusted springs or poorly functioning door mounts or door constructions.

Before installing the drive...:

- ◆ ...remove all unnecessary ropes or chains and switch off any equipment, such as locks, not needed for powered operation.



During installation there is a risk of injury due to the unsecured door falling suddenly.

- ◆ During the installation work, ensure that there are no persons in the swivelling area of the garage door.



Faulty installation can result in serious accidents and injuries.

- ◆ Fit the actuator for the emergency release at a height of less than 1.8 metres.
- ◆ Use only the enclosed mounting materials and only original spare parts and original accessories.
- ◆ Any existing door locking devices already fitted to the door may hinder the correct functioning of the door and must therefore be removed.
- ◆ Movable parts of the garage door must not extend into public footpaths or cycle paths.
- ◆ Poor lighting hinders the installation work and can result in injuries. Ensure that there is adequate lighting during installation work.
- ◆ It is possible that during the installation work, you may not be able to open the door for a short period of time.
- ◆ This drive is not to be used with doors having openings exceeding 50 mm in diameter or having edges or protruding parts a person could grip or stand on.
- ◆ Permanently fix the labels warning against entrapment in a prominent place or near any fixed controllers.
- ◆ Permanently fix the label concerning the manual release adjacent to its actuating member.



10.1 Required tools

EN

You require the following tools for installation:

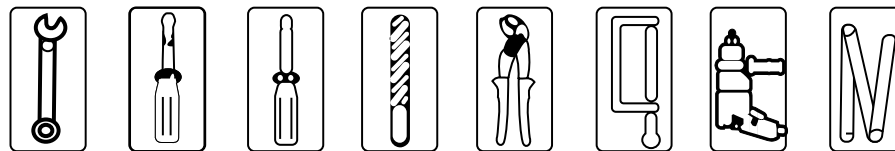

10.2 Remove the door locks

1. **Remove all vertical and horizontal door locks and catches.**

NOTE!

Keep the old door locks in a safe place.

In the event that you should remove the garage door drive, you will have to fit these again in order to restore the original state of the door.





10.3 Take measurements

EN

1. Measure up and mark the centre of the door.

Mark the centre of the door, as shown, on the upper edge of the door, on the door lintel and on the garage ceiling.

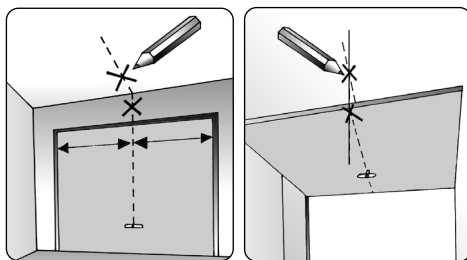

2. Determine the distance between the top edge of the door and the ceiling.

Close the door slowly and measure the distance between the top edge of the door and the ceiling.

NOTE!

The minimum distance should be 4 cm.

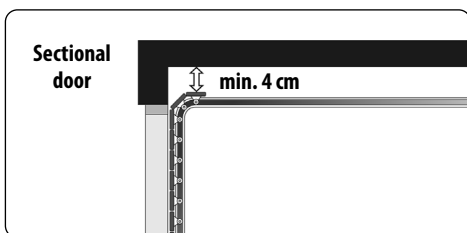
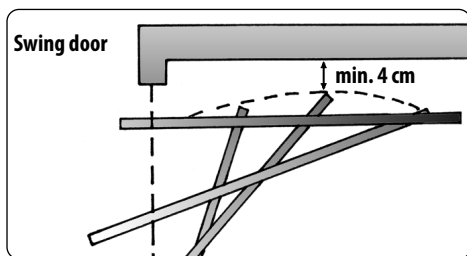

3. Installation advice for fitting to sectional doors.

If the garage door drive is being used for a sectional door, then the guide roller of the upper door segment must be in the bend of the guide rail when the door is closed.

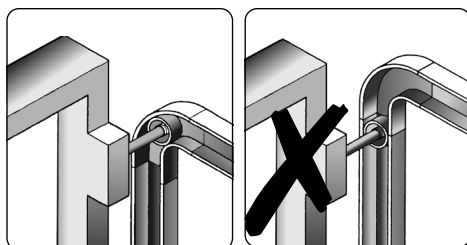

Correct

Wrong



10.4 Assembly of the rails

EN

NOTE!

The RolloPort SX5 DuoFern is supplied with three rails:

- ◆ two end pieces, including a pre-mounted toothed belt.
- ◆ a middle piece (without toothed belt) with two connectors.

1. Lay the two end pieces with the pre-mounted toothed belt on the ground, with the chain lying as straight as possible between the two end pieces.

2. Push the two enclosed connectors onto the middle piece and then lay the middle piece in the gap between the two end pieces.

3. Insert the toothed belt into the middle piece.

4. Push each of the connectors onto the join between the middle piece and each of the end pieces.

Please ensure that each of the connectors lies in the centre between the fixing plates of the rail underside.

5. Finally, bend the fixing plates outwards with a small screwdriver.

As a result, the connectors can no longer be moved.

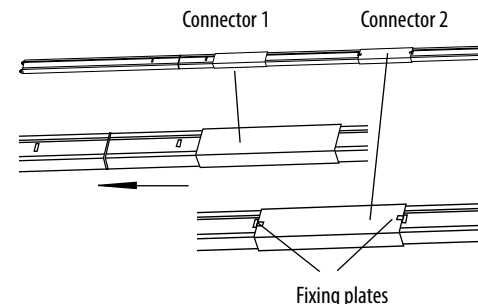

10.5 Tension the toothed belt

1. Screw the clamping nut tight with a suitable socket key (Ø 10 mm).

2. Adjust the tension of the toothed belt as shown in the picture.

NOTE!

Due to manufacturing tolerances, the shown range of approx. 36 - 38 mm can vary.

Ensure that the toothed belt is allowed to sag slightly along the entire rail length, so that it is not excessively tight. An excessively tight toothed belt can lead to drive power loss.

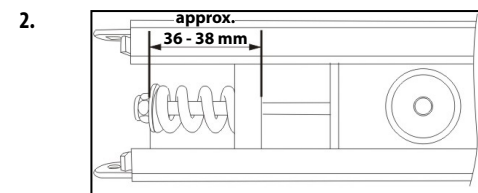
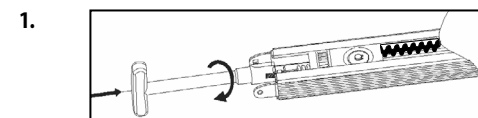



10.6 Connect the door drive housing to the rail

EN

1. First of all insert the connector (5).
2. Place the rail (4) with the inboard chain sprocket (supplied pre-mounted into the rail) over the connector (5).
3. Place the two fixing brackets (2) over the rail (4) and screw these firmly onto the drive housing with the enclosed self-tapping hexagon screws (6 x 15 mm).

IMPORTANT

Ensure that the microswitch (3) is not damaged when mounting the rail.

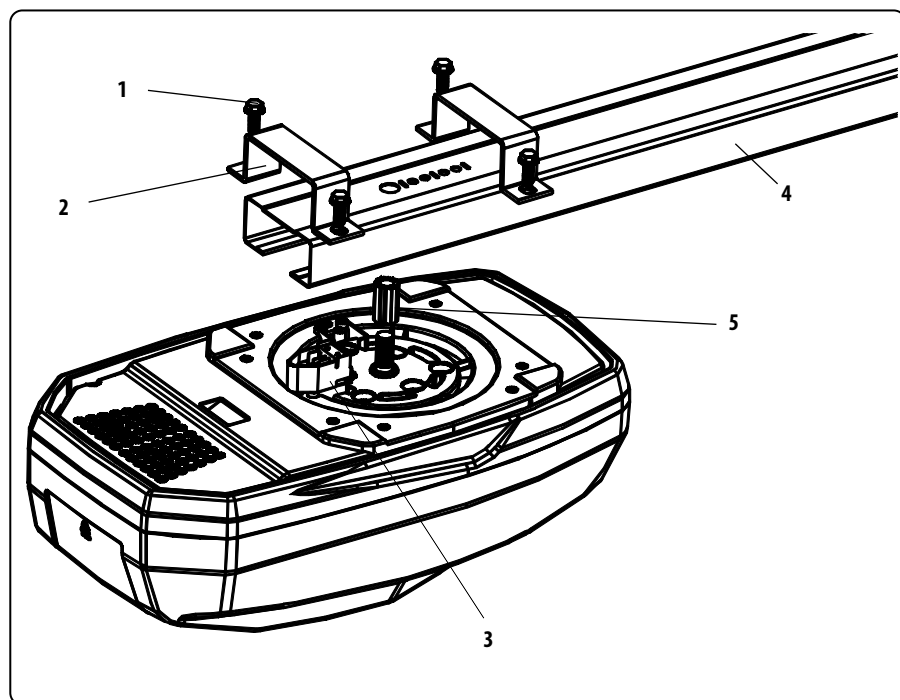

Legend

- 1 = Self-tapping hexagon screws (6 x 15 mm)
- 2 = Fixing brackets
- 3 = Microswitch
- 4 = Rail
- 5 = Connector

NOTE!

Alternatively you can install the drive transversely to the rail, e. g. if space is tight (see following page).



10.7 Connect the door drive housing to the rail (90° drive assembling)

EN

Alternative installation of the drive transversely to the rail.

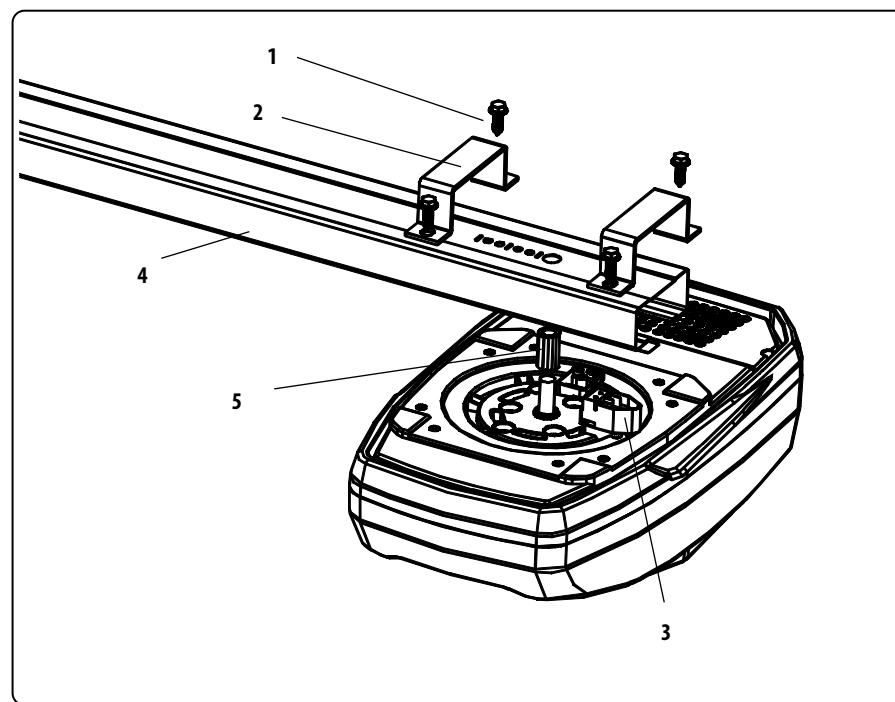

NOTE!

The microswitch (3) must always be positioned at the end of the rail. For this reason, the microswitch (3) must be correspondingly moved if the drive is installed transversely (see figure above).



Mortal danger due to electric shock when undertaking any work on the microswitch (3).

- ◆ Arrange for a qualified electrician to move the microswitch (3).
- ◆ The microswitch (3) may only be moved if the system is fully de-energised.
- ◆ Always remove the mains plug and secure it to prevent it being switched back on prior to undertaking the work.
- ◆ Check that the system is de-energised.



10.8 Attachment of the drive and rail

EN

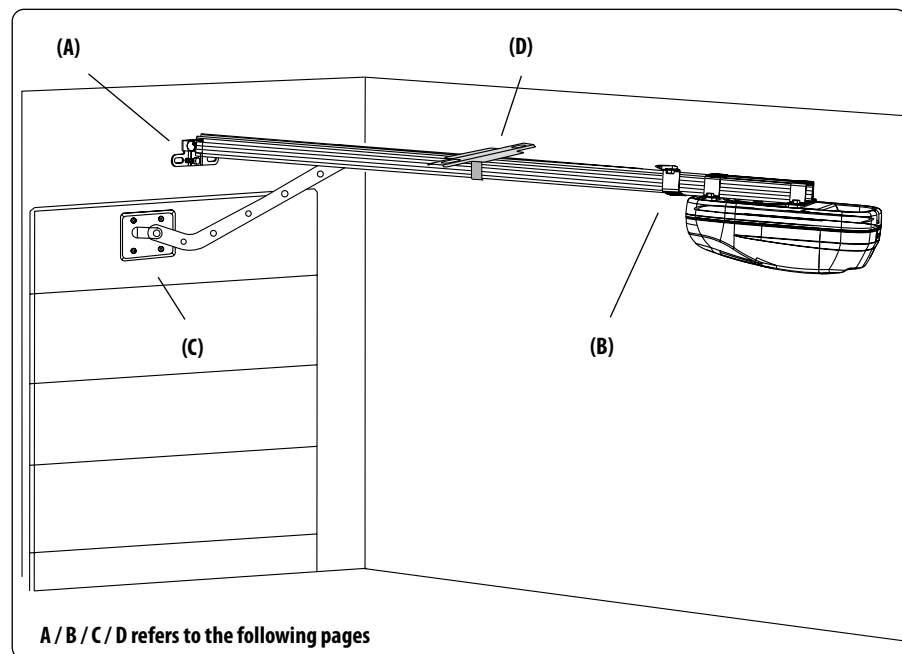

Installation on the lintel

The installation should preferably be on the lintel, as this means that the forces encountered can best be absorbed.

Installation on the ceiling

For installation on the ceiling, you should rotate the header bracket by 90 degrees and fix it to the ceiling further inward. The full rail length can then be used as a result.

NOTE!

- ◆ When fitted to the ceiling, the distance to the door leaf must be a maximum of 25 cm. Otherwise perforated brackets must be used, see page 23, Chapter "10.13 (E) Installation on the ceiling with perforated brackets".
- ◆ In the case of garage walls or garage ceilings made of stone (concrete), use the enclosed hexagon screws (8 x 60) and wall plugs \varnothing 10 mm.

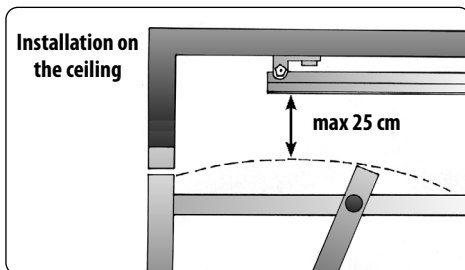
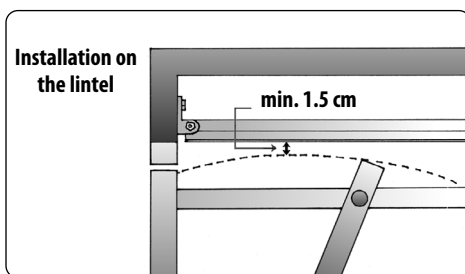

10.9 (A) Installation of the header bracket (1)

EN

NOTE!

The header bracket (1) must be aligned with the mid-point of the door.

1. Mark out the position of the header bracket (1) and drill the mounting holes (e. g. with a 10 mm masonry drill bit).
2. Screw the header bracket (1) tight with the enclosed hexagon screws (3) [8 x 60 mm].
3. Subsequently guide the rail (4) and protective sleeve (2.1) between the ends of the lintel bracket (1) and push the screw (2) [6 x 80 mm] through from the outside.
4. Finally secure the rail (4) by tightening the hexagon nut.

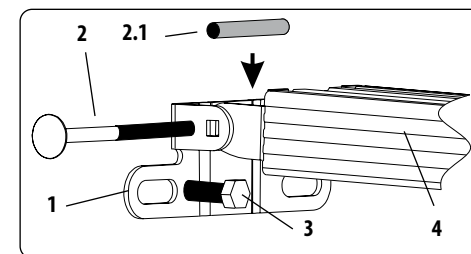

Legend

- 1 = Lintel bracket
- 2 = Bolt (6 x 80 mm) with hexagon nut
- 2.1 = Protective sleeve
- 3 = Hexagon screw (8 x 60 mm)
- 4 = Rail



10.10 (B) Installation of the fixing bracket (5) at the drive head (7)

1. Push the fixing bracket (5) onto the rail (4), as close to the drive head (7) as possible.
2. Mark the mounting holes for the fixing bracket (5).

In order to do so, lift the entire construction and push it against the ceiling.

NOTE!

Ensure that the rail (4) is aligned with the centre of the door.

3. Drill the mounting holes (e. g. with a 10 mm masonry drill bit).
4. Finally screw the fixing bracket (5) to the garage ceiling with the enclosed hexagon screws (8 x 60 mm).

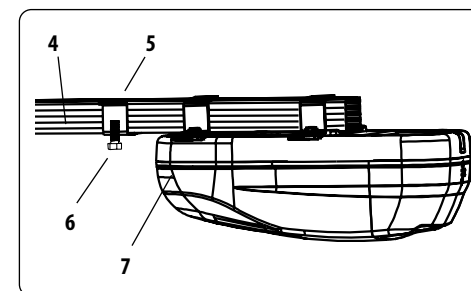

Legend

- 4 = Rail
- 5 = Fixing brackets
- 6 = Hexagon screw (8 x 60 mm)
- 7 = Drive head



10.11 (C) Installation of the door bracket (8)

EN

NOTE!

- ◆ We recommend fixing the door bracket (8) to the door frame if possible.
- ◆ For plastic or thin-walled wooden doors, additional cross-beams are necessary in order to avoid damaging the door. In this case, consult your door supplier.
- ◆ Use existing drill holes, if possible, to mount the door bracket (8).

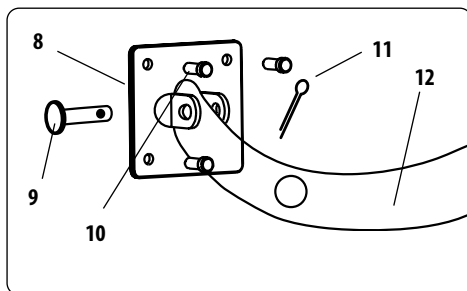

Legend

- 8 = Door bracket
- 9 = Bolts (8 x 20 mm)
- 10 = Self-tapping hexagon screws (6 x 15 mm)
- 11 = Securing bolt (2 x 20 mm)
- 12 = Door connector, bent

1. Place the door bracket (8) on the top edge of the garage door and align it with the centre of the door (in a line with the profile slide). Next, mark out the four fixing holes on the door frame.



2. Punch in the fixing holes in the door frame with the aid of the enclosed spike.

NOTE!

Self-tapping screws need sufficient purchase in the material. Check the thickness of your door frame. If it is sufficiently thick you can also pre-drill the fixing holes with a 4 mm metal drill bit if you are not able to punch in the holes with the spike.

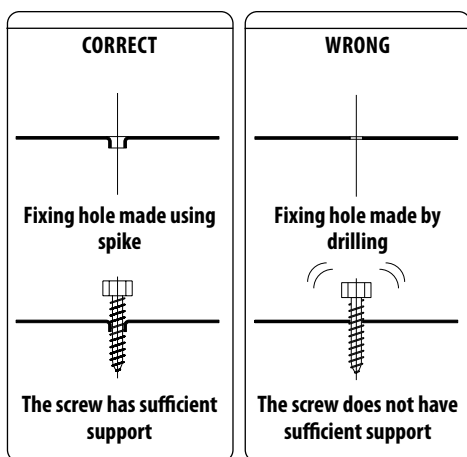

10.11 (C) Installation of the door bracket (8)

EN

3. Screw the door bracket (8) tight to the frame with the enclosed self-tapping hexagon screws (8 x 15 mm).
4. Finally, fix the door connector (12) to the door bracket (8) with the enclosed bolt (9).

NOTE!

- ◆ A straight door connector is supplied pre-mounted, and this is permanently fixed to the rail.
 - ◆ If you wish to use the bent door connector (12) enclosed (depending upon your door particular configuration), you must attach this with two hexagon screws (8 x 20) to the straight door connector.
5. Finally, secure the bolt (9) by attaching the securing bolt (11) to prevent it from slipping out.

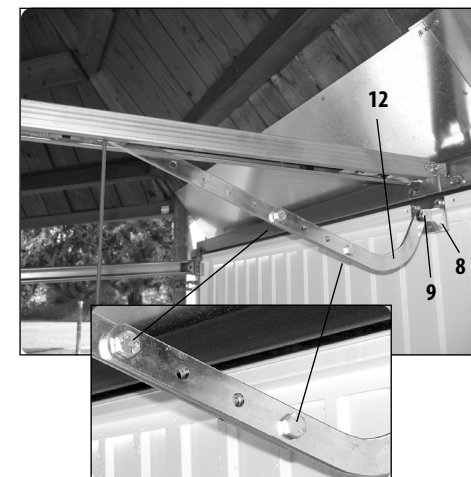

10.12 (D) Installation of the middle support clip (13)

1. Fit the middle support (13) clip at a suitable place, as near as possible to the middle point between the door and the drive head.

Legend

- 13 = Centre suspension
- 14 = Hexagon screws (8 x 60 mm)

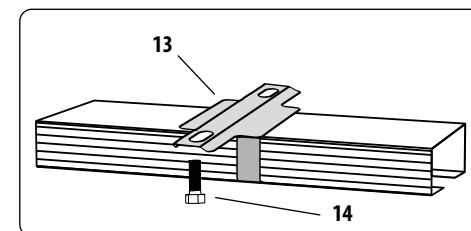

10.13 (E) Installation on the ceiling with perforated brackets

If mounting directly on the ceiling is not possible due to the ceiling height being too high, the perforated brackets must be used for the suspension because there is a distance of more than 25 cm between the highest point of the door and the rail.

To do this, bend the brackets to the desired length and then connect them to the mounting bracket and the centre suspension.

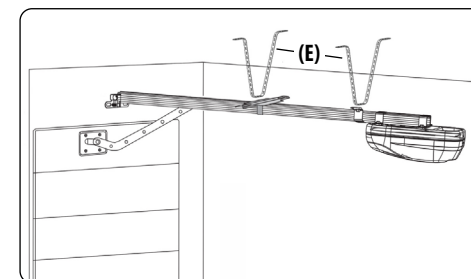



10.14 Important notes after installation

EN



◆ Ensure that the mechanism is properly adjusted and that the drive reverses when the door contacts a 50 mm high object placed on the floor (for drives incorporating an entrapment protection system depending on contact with the bottom edge of the door), see page 13.

◆ Ensure that the drive prevents or stops the opening movement when the door is loaded with a mass of 20 kg, fixed centrally on the bottom edge of the door. This applies especially to drives which can be used with a door that has openings in the door leaf larger than 50 mm in diameter.



10.15 Attach safety notices with warning information



Improper use results in an increased risk of injury.

- ◆ Permanently fix the labels warning against entrapment in a prominent place or near any fixed controllers.
- ◆ Permanently fix the label concerning the manual release adjacent to its actuating member.
- ◆ Attach all labels so that they are clearly legible.



10.16 Establish operational readiness of the door

1. Move the door carefully, in order to engage the profile slide.
2. Plug the mains plug into the socket and switch on the electricity.
3. The light goes on and the unit gives a single beep and the display shows '0' at regular intervals.



11. Programming



In order that the following settings are correctly stored and executed, you must carry out a final programming procedure according to page 32.



11.1 Setting end points / setting the upper end point

EN



Carrying out the instructions in the wrong order when setting the end points will result in malfunctions. Be sure to keep to the setting order specified.

Correct setting order:

1. Set upper end point
2. Set lower end point

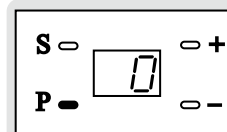

1. Press "P" for approx. 5 seconds.

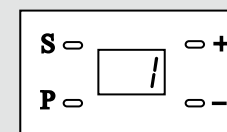

2. The drive beeps and shows "1".

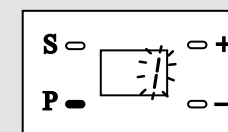

3. Press "P", "1" flashes.

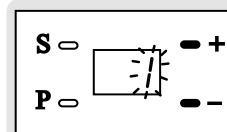

4. Press "+" or press "-".

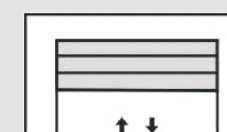

5. The door opens or closes.

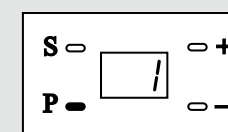

6. If the door has moved upwards to the required position, press "P" to save the upper end point.



11.2 Setting the lower end point

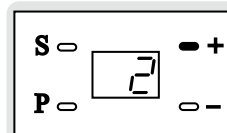

1. Press "+", the display shows "2".

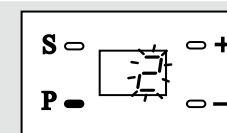

2. Press "P", "2" flashes.

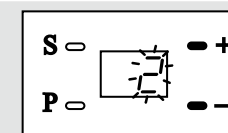

3. Press "+" or press "-".

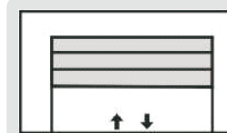

4. The door opens or closes.

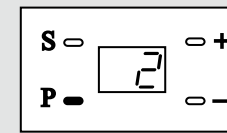

5. If the door has moved downwards to the required position, press "P" to save the lower end point.



11.3 Carry out reference run for power measurement

EN



During the reference run there is a risk of injury, as the drive develops extremely strong forces.

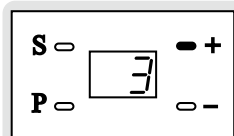

1. Press "+", the display shows "3".

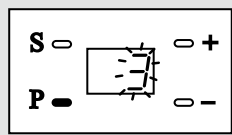

2. Press "P", "3" flashes.



3. The door goes up automatically.

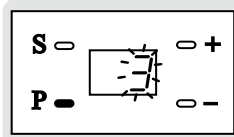

4. After it has stopped, press the "P" button twice.



5. The door goes down.

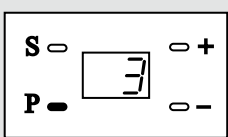

6. After it has stopped, press "P", to save the information.

"0" will be displayed at regular intervals in order to conclude the programming and set the drive in to an idle state.

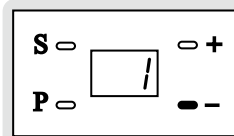

7. Conclude programming (refer to page 32 / method 1).

NOTE!

- ◆ Once you have set the two end points and the reference run for power measurement, you have fulfilled the basic settings required for safe operation.
- ◆ If you do not require any further settings, you must conclude programming as specified in **Method 1** on page 32, in order to adopt the basic settings you have just programmed.
- ◆ After this, you can conclude the following individual settings, either singly or after all the settings have been programmed, using **Method 2** on page 32.



11.4 Adjust power limiting as required

EN

NOTE!

The drive is preset to stage 3 by the supplier. If required (e. g. if the power level is too low) you can subsequently adjust the power limiting setting.



If the power level is too low, the door movement will be impaired, particularly if the mechanical structure of the door is not well balanced.

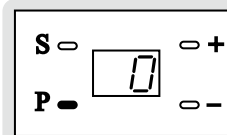

1. Press "P" for approx. 5 seconds.

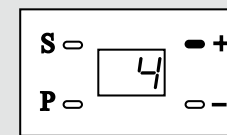

2. Press "+".
(if necessary press several times) until "4" is displayed.

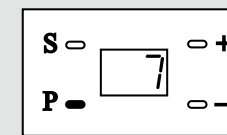

3. Press "P", the display shows "7" (stage 3).

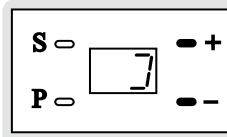

4. Press "+" or press "-" to select the stage.

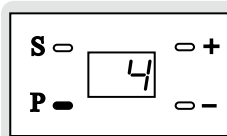
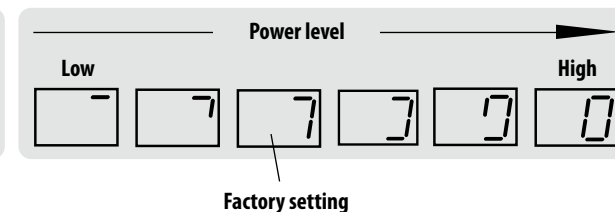

5. Press "P", in order to store the setting.

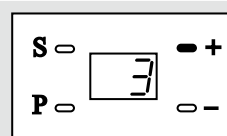

6. **IMPORTANT**
Repeat reference run for power limiting (refer to page 26).

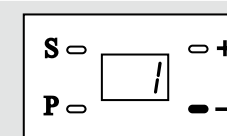

7. Conclude programming (refer to page 32 / method 1).



After resetting of the power level, it is absolutely necessary to repeat the reference run for power limiting and to conclude the programming again.

- ◆ Risk of injury if reference run is not undertaken for purposes of power measurement. Also there is a risk of injury during the reference run process, as the drive develops a high degree of force.
- ◆ If the subsequent adjustment does not restore correct operation, please contact our authorised Service department.



11.5 Alarm setting

(can also be configured via SmartHome Box)

EN



If the alarm is switched on, the drive beeps if the door is open for longer than 10 minutes. The signal tone is emitted for 30 seconds every 10 minutes.

To end the beeping:

Press the door control button to fully close the door.

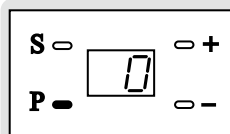

1. Press "P" for approx. 5 seconds.

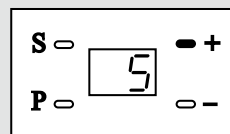

2. Press "+"
(press several times if necessary) until "5" is displayed.

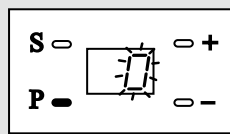

3. Press "P", the display is "0".
(0 = off = factory setting)

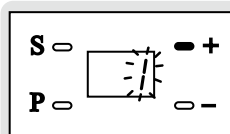

4. Press "+", the display is "1".
(1 = on = the alarm setting is switched on)

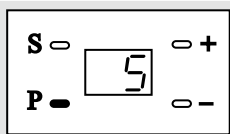

5. Press "P" in order to store the alarm setting.

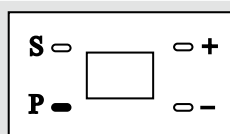

6. Conclude programming (see page 32 / Method 2) or proceed with next setting.



11.6 Automatic closing time setting

(can also be configured via SmartHome Box)

NOTE!

Before the door closes automatically, the drive beeps for 20 seconds. At the same time the light flashes.

When the door starts closing, the light shines durably and it beeps permanently.

After the door has closed, the drive ends the beeping and the light remains on for a further 3 minutes.

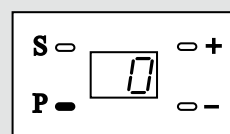

1. Press "P" for approx. 5 seconds.

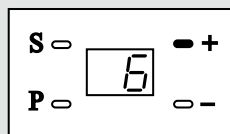

2. Press "+"
(if necessary press several times) until "6" is displayed.

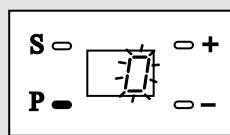

3. Press "P", the display is "0".
(0 = off = factory setting)

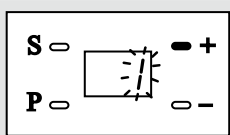

4. Press "+", the display is "1".
(1 = on = automatic closing time = 30 seconds).



11.6 Automatic closing time setting

(can also be configured via SmartHome Box)

EN

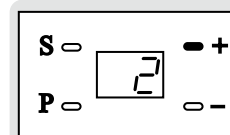

5. Press "+" and select the required closing time:

1 = 30 s 5 = 150 s
2 = 60 s 6 = 180 s
3 = 90 s 7 = 210 s
4 = 120 s 8 = 240 s
(maximum)

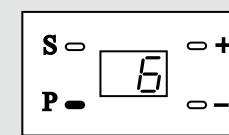

6. Press "P" in order to store the setting.

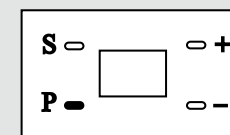

7. Conclude programming (see page 32 / Method 2) or proceed with next setting.



11.7 2000 cycle alarm setting

(can also be configured via SmartHome Box)



After a period of time in use, regularly check to see whether the door is level when opening/closing, and whether the spring has enough force to raise the door.

Add a suitable amount of lubricant to all moving parts regularly.

NOTE!

If this function is activated, after 2000 cycles the drive will indicate with a short whistling tone at regular intervals that door maintenance must be carried out.

To end the alarm tone

Switch the power off and back on again, or press the "P" button for 5 seconds.

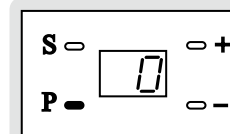

1. Press "P" for approx. 5 seconds.

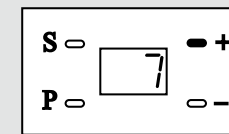

2. Press "+"
(if necessary press several times) until "7" is displayed.

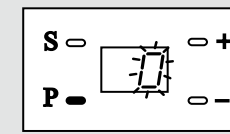

3. Press "P", the display is "0".
(0 = off = factory setting)

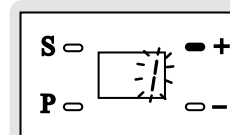

4. Press "+", the display is "1".
(1 = on)

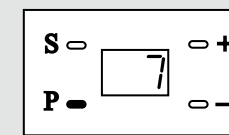

5. Press "P" in order to save the setting.

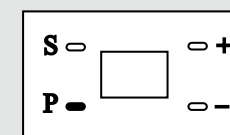

6. Conclude programming (see page 32 / Method 2) or proceed with next setting.



11.8 Opening speed setting

(can also be configured via SmartHome Box)

EN

With this function you can set the speed of the upwards movement to your individual requirements.

Configuration of the upwards movement speed is set in cm/s (centimetres per second).

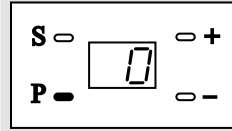

1. Press "P" for approx. 5 seconds.

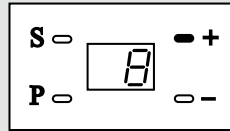

2. Press "+".
(press several times if necessary) until "8" is displayed.

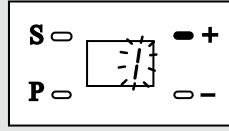

3. Press "P", the display is "1".
1 = 11 cm/s opening speed
3 = 19 cm/s = factory setting

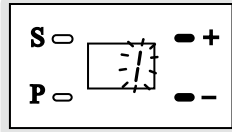

4. Press "+" or "-" and select the desired opening speed.

1 = 11 cm/s
2 = 15 cm/s
3 = 19 cm/s (maximum)

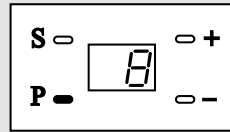

5. Press "P" in order to store the setting.

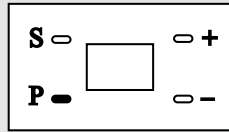

6. Conclude programming (see page 32 / Method 2) or proceed with next setting.



11.9 Back-jump function setting

(can also be configured via SmartHome Box)

EN

Function

After closing, the jump-back function relieves the drive components by briefly moving in the opposite direction (10 mm).

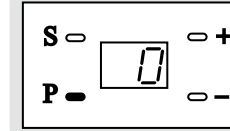

1. Press "P" for approx. 5 seconds.

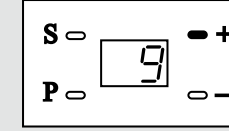

2. Press "+".
(press several times if necessary) until "9" is displayed.

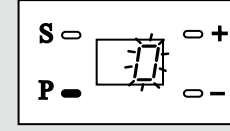

3. Press "P", the display is "0".
(0 = off = factory setting)

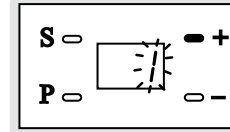

4. Press "+", the display is "1".
(1 = on = the back-jump function is switched on)

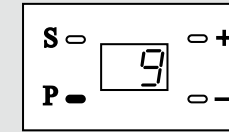

5. Press "P" in order to store the setting.

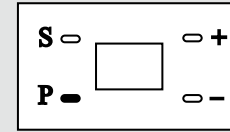

6. Conclude programming (see page 32 / Method 2) or proceed with next setting.



11.10 Conclude programming

EN

NOTE!

- ◆ Please note: **this concluding step must be carried out**, otherwise the information stored will be lost.

The following applies to RolloPort SX5 DuoFern:

The programming must be completed so that you can make settings in the DuoFern network or on the SmartHome Box.

You can conclude the programming in two ways:

Method 1: Carry out this method without fail after the reference run.

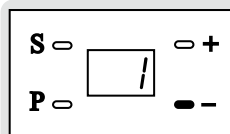

1. After the reference run, press "-".

(press several times if necessary) until "1" is displayed.

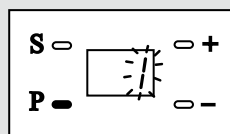

2. Keep "P" pressed for 5 seconds.

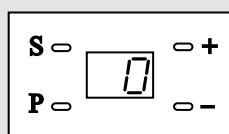

3. "0" will be displayed at regular intervals in order to conclude the programming and set the drive into an idle state.

Method 2: After all other settings

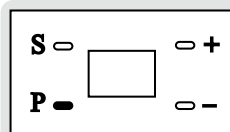

1. After completing any setting, press "P" for 5 seconds.

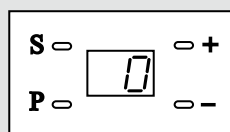

2. "0" will be displayed at regular intervals in order to conclude the programming and set the drive into an idle state.



12. Logging on/off manual transmitters and/or DuoFern SmartHome Box

EN

Logging on manual transmitters or DuoFern transmitters:

Both manual transmitters are already logged on to the large button on the garage door drive when in the factory. If you want to log on another manual transmitter, or have already logged off a manual transmitter that is included in the scope of supply and want to log it on again, proceed as follows.

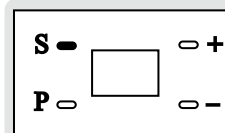

1. Press "S" for approx. 2 seconds and then let go.



2. Two green dots flash briefly at the bottom of the display by way of confirmation.

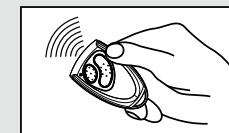

3. Logging on a manual transmitter.

- ◆ Press twice the button on the manual transmitter you want to use to operate the garage door drive. A signal tone is emitted by the drive during the log-on process by way of confirmation.



4. Logging on a DuoFern transmitter or a SmartHome Box.

- ◆ Switch the DuoFern transmitter or the SmartHome Box to registering mode.

Login is undertaken automatically. If registration is successful, the left-hand dot lights up for approx. two seconds.

NOTE!

After successfully registering you can operate your garage door drive with the manual transmitter. You can register a maximum of 16 additional manual transmitters.

RolloPort SX5 DuoFern

You can register a maximum of 20 additional DuoFern transmitters.

Logging off manual transmitters or DuoFern transmitters:



For security reasons, a manual transmitter must be de-registered in the event of loss, to prevent the garage door from being operated by unauthorised persons.

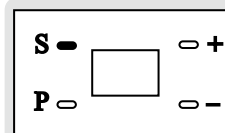

1. Press and hold "S" for 8 seconds.

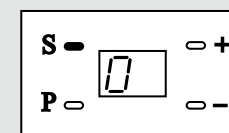

2. The "0" goes out in the display. All manual transmitters are logged off.

RolloPort SX5 DuoFern
All DuoFern transmitters are logged off.



13. Application and installation of a light barrier

EN

As an additional safety device you can equip the RolloPort SX5 DuoFern garage door drive with a light barrier (item no. 8000 00 51).

Applies additionally to RolloPort SX5 DuoFern

- ◆ Garage doors with automatic closing (e.g. RolloPort SX5 DuoFern) must be fitted with an additionally connected safety device (e.g. light barrier), in addition to the standard equipped power limiter.
- ◆ The RolloPort SX5 DuoFern may only be used in automatic mode (automatic closing) with an additionally connected light barrier.

Functional description for operation with a light barrier

If the signal from the light barrier is interrupted while the door is closing, the garage door drive stops and then moves to the upper end point.

Installation of a light barrier

Please refer to the respective operating manual.



Electrical connection of a light barrier

See page 35.



14. Connecting additional electrical equipment



When working on electrical systems there is a risk of danger to life due to electrocution.

- ◆ The connection of additional electrical equipment must only be carried out by a qualified electrician.
- ◆ Before opening the protective cover always disconnect the equipment from the mains power supply and check that the system is free of voltage.



Accessories from other manufacturers may result in malfunctions or damage to property.

- ◆ Use only original accessories. A separate source voltage at the screw type terminal for the external switch will result in a short circuit and will destroy the drive's electronics.



If external switches are not connected properly, the operational safety of the equipment is at risk.

Always mount the internal switch, code switch, etc.:

- ◆ outside the range of movable parts
- ◆ within visibility of the door
- ◆ at a height of at least 1.5 metres

NOTE!

In order to make the electrical connection for the RolloPort SX5 DuoFern, it is necessary to release the two screws from the protective hood (2) and take the protective hood (2) off the drive.



If a wicket door is installed, the door position must be monitored. It must be ensured that the drive is not active if the door is not closed.



14.1 Connection diagram for additional electrical equipment

EN

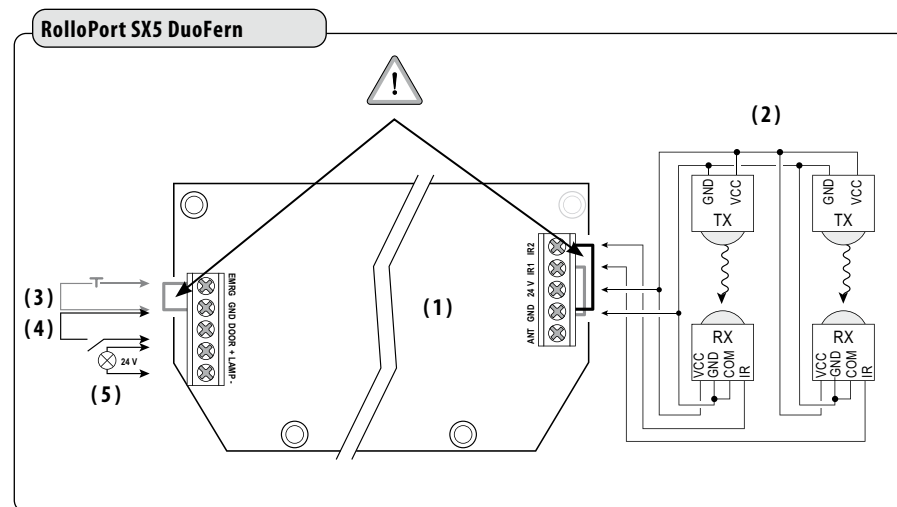

Legend

- (1) = main board
- (2) = infrared light barrier (optional)
- (3) = pass door contact
- (4) = external switch (optional)
- (5) = Signal lamp (24 V)

* The signal lamp flashes as long as the drive moves. It is not a permanent light.



NOTE!

Remove the respective factory installed bridge before connecting a light barrier or a pass door contact.



15. Manual door operation

EN

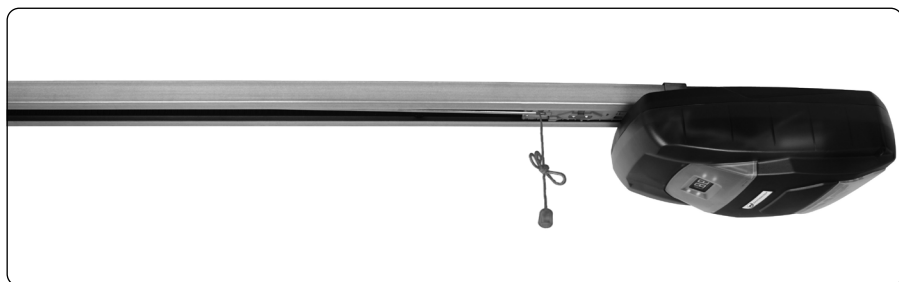

In the case of power failure:

1. If you wish to manually operate the door in the event of a power cut, you must pull the emergency release cable so that this releases the door from the drive.

After that you can move the door freely.



There is a risk of injury. The door can fall down uncontrollably when released (e. g. if the door is not balanced)

- ◆ Close or open the door fully after each release.
- ◆ The emergency release is not intended for everyday use.

If power recovers:

1. Operate the manual transmitter or the wall switch.

NOTE!

Engagement occurs automatically.



16. Instructions for the user

EN

Notes for use.

- ◆ Check the drive system to determine whether it moves smoothly the first time the garage door drive is used.
- ◆ After some time in use, check regularly to see whether the door remains horizontal when opening and closing and whether the spring has enough power to lift the door. Lubricate all movable parts regularly with a suitable lubricant.
- ◆ In the event of a power cut, you can pull the emergency release and freely move the door manually.

- ◆ When the power is back, you can operate the manual transmitter or the wall panel, and the emergency release will engage automatically.
- ◆ The door can then be operated again with the manual transmitter or the wall panel.

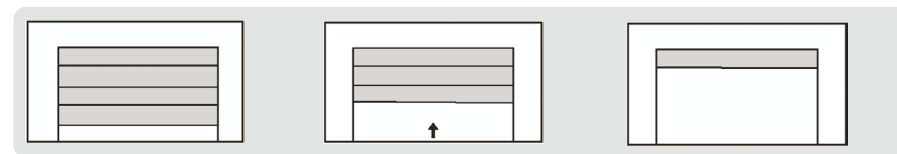

1. In the event of a power cut, the door stops moving.

2. Once the power is back on, press a button on the manual transmitter, and the door will open. The door opens.

3. In accordance with the programmable memory, the door lifts to the upper end point and then stops.

Normal operation

◆ Remote control

By pressing the manual transmitter, the door can be opened, closed or stopped.

◆ Manual operation

In the event of a power cut, the door can be opened or closed manually as soon as the door drive has been disengaged (refer to page 36).

Power:	150 W
Supply voltage:	220 - 240 V / 50 - 60 Hz
Motor:	24 V (DC)
Drive type:	Toothed belt
Standby consumption:	
- RolloPort SX5 DuoFern:	< 1 W
Tractive force:	max. 900 N / 90 kg
Speed of door operation:	
- Opening direction:	11 / 15 / 19 cm / second (adjustable)
- Closing direction:	11 cm / second
Permissible ambient temperature:	-10 to + 40 °C
Illumination:	Integrated power LED with time limit
Overall length:	
- standard assembling:	3475 mm
- with 90° assembling:	3335 mm
Maximum lift:	2550 mm
Manual transmitter radio frequency:	433 MHz rolling code
Transmission frequency RolloPort SX5 DuoFern:	434.5 MHz
Transmission power RolloPort SX5 DuoFern:	max. 10 mW
Max. number of DuoFern devices:	20
Radio range RolloPort SX5 DuoFern:	max. 50 meters in open areas max. 30 m in buildings, depending on the building structure
Noise pressure level (LpA):	≤ 70 dB(A)

i 17.1 Permitted garage door dimensions

Maximum door size:	max. 5.5 m x 2.55 m, 14.025 m ² (for sectional doors); max. 5 m x 2.3 m, 11.5 m ² (for one-piece doors)
Minimum lintel height:	4 cm
Maximum infill weight for up-and-over doors:	157 kg (for sectional doors); 126 kg (for one-piece doors)

Fault	Causes	Solution
The drive does not work.	<ol style="list-style-type: none"> 1. The plug is not inserted properly. 2. The fuse has been tripped. 	<ol style="list-style-type: none"> 1. Plug the mains plug into the mains socket. 2. Have the cause checked by a qualified engineer, then reset the fuse.
The manual transmitter cannot actuate the drive.	<ol style="list-style-type: none"> 1. The manual transmitter may have been wrongly registered or has not been registered at all. 2. The battery is dead. 	<ol style="list-style-type: none"> 1. Register the manual transmitter again, refer to page 33. 2. Replace the battery.
The range of the manual transmitter is too low.	The battery may be dead.	Replace with a new one of the same model.
The toothed belt moves, but the door does not.	The emergency release may have been triggered.	Operate the drive until the emergency release engages again automatically.
The toothed belt has some sag and is noisy.	The toothed belt is slack due to the reduced tension of the belt.	Tension the toothed belt as described on page 17.
The door does not move and the screen is blank. The red LED on the printed circuit board has come on.	The door system is not well balanced and causes excessive peak power. This causes the protective function of the drive to be triggered.	Switch off the mains power for a minimum of 3 minutes. Then adjust the door system and make sure that it is well balanced.
Error message "F/H" appears in the display.	<p>A fault has been detected by the electronics.</p> <p>Possible cause:</p> <ul style="list-style-type: none"> ◆ Excessive force ◆ The pass door contact has triggered. ◆ A fuse has blown. 	Eliminate the cause of the fault or arrange to have your door checked by a specialist.
Error message "A" appears in the display.	The light barrier has been interrupted.	<ol style="list-style-type: none"> 1. Check whether a person or an obstacle is located within the monitoring area of the light barrier. 2. Remove any obstruction.

i 19. Simplified EU Declaration of Conformity

EN



DELTA DORE RADEMACHER GmbH hereby declares that the RolloPort SX5 DuoFern complies with the Directives **2006/42/EC (Machinery directive)** and **2014/53/EU (Radio Equipment Directive)**.

The full text of the EU declaration of conformity is included with the product and is kept on file by the manufacturer.s.

DELTA DORE RADEMACHER GmbH
Buschkamp 7
46414 Rhede (Germany)

Warranty terms and conditions

Information on our warranty conditions is enclosed separately with this product.

i 20. Environmentally compatible disposal



This product must not be disposed of with household waste. This product must be disposed of at an authorised site for the recycling of electronics and electrical appliances.

Through collection and recycling of waste you can help to conserve natural resources and ensure that products are recycled in an environmentally friendly manner.

i

EN

DELTA DORE RADEMACHER GmbH
Buschkamp 7
46414 Rhede (Germany)